

Typ
Type
Typ

- M 25
- M 40
- M 50
- M 71
- M 90
- F 50
- F 63
- F 80
- F 100
- W 25
- W 40
- W 50
- W 71
- W 90
- ML 40
- ML 50
- ML 71
- ML 90
- MA 40**
- MA 50
- ME
- FE

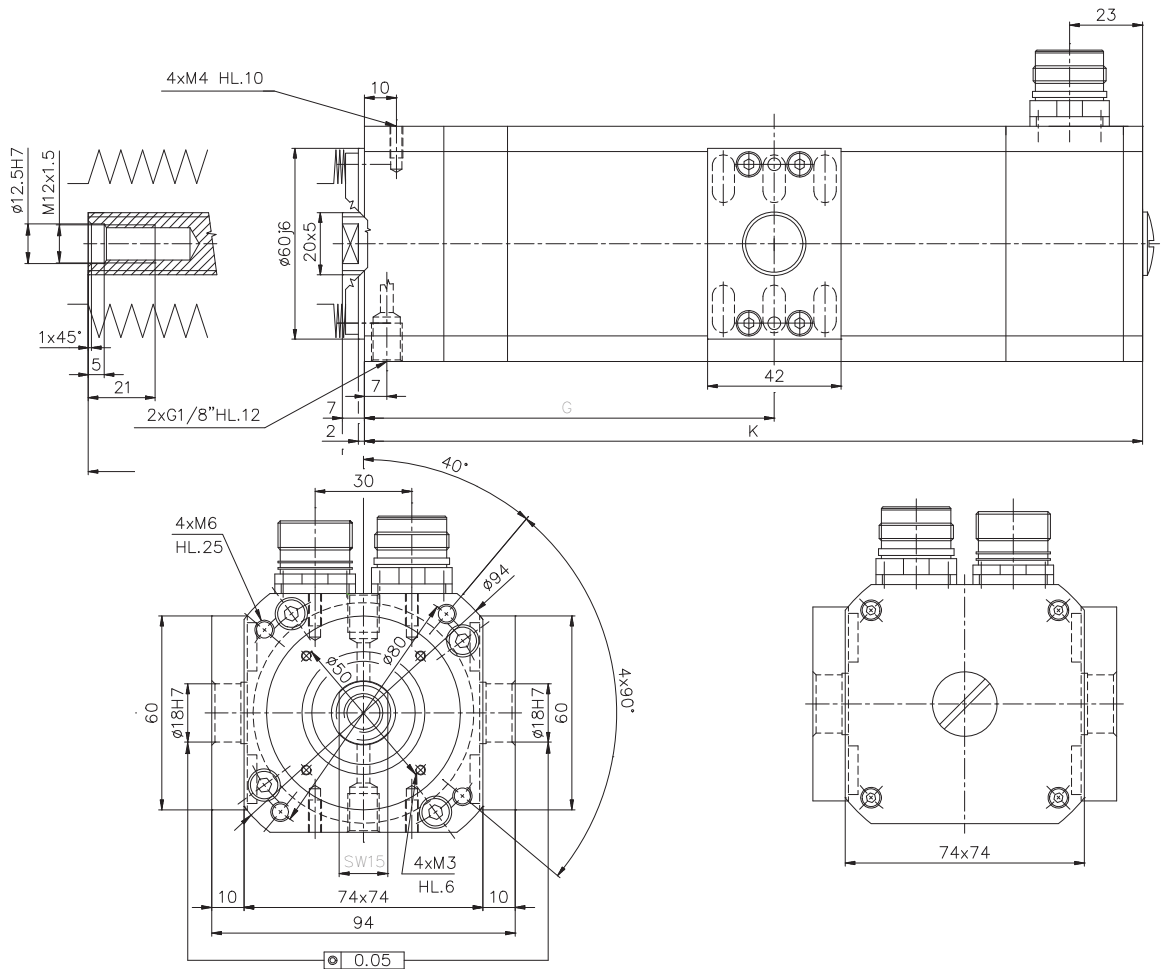

MA 404
MA 406
MA 408



TYP SERVOMOTORU			
MOTOR TYPE	K	H	G
MOTORTYP			
MA 404	205	70	105
MA 406	245	110	120
MA 408	285	150	140



◆ Radiální a axiální zatížení volného konce ◆ Radial and axial shaft load capacity ◆
◆ Zulässige Radial- und Axialbelastungen der Wellenenden ◆

POZOR : ŽÁDNÉ RADIÁLNÍ ZATÍŽENÍ LOŽISKOVÉHO ŠROUBU !!!
ATTENTION : NO RADIAL LOAD CAPACITY OF A BALL SCREW !!!
VORSICHT : KEINE RADIALBELASTUNGEN DER KUGELGEWINDEANTRIEBEN !!!

		MA 404	MA 406	MA 408
F_{MAX}	N	10000	10000	10000
v_{MAX}	mm.s ⁻¹	260	260	260
n_{MAX}	rpm	3200	3200	3200

F_{MAX} - Maximální axiální zatížení ložiskového šroubu / Maximal axial load capacity of a ball screw / Maximale Axialbelastungen der Kugelgewindeantrieben /
 v_{MAX} - Maximální rychlost posuvu / Max. speed of shift / Maximale Verfahrensgeschwindigkeit
 n_{MAX} - Maximální otáčky / Maximal speed / Max. Drehzahl

◆ Konektory ◆ Connectors ◆ Stecker ◆

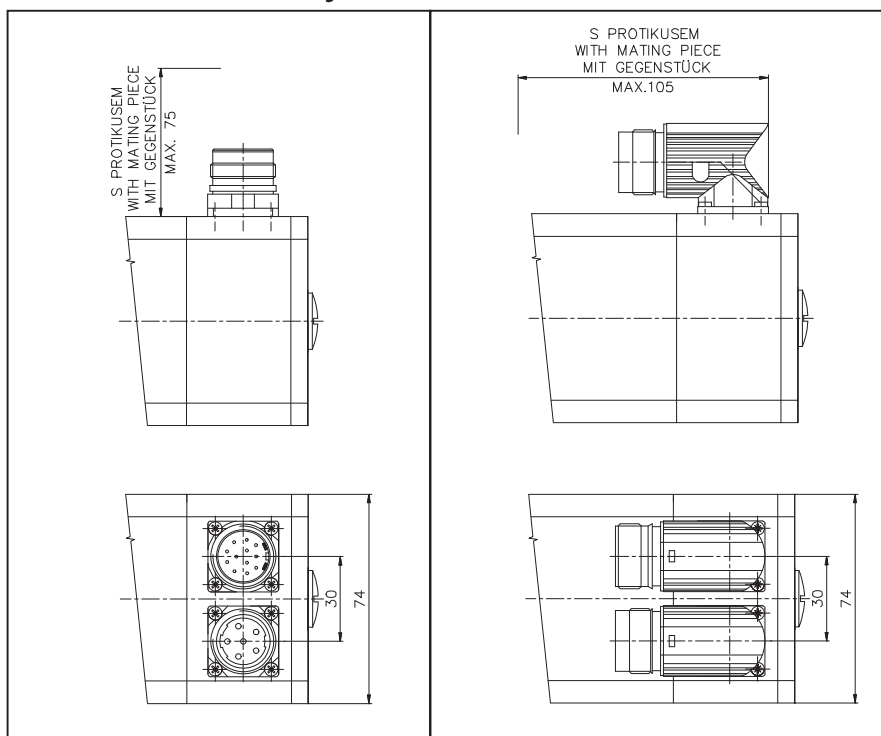

Motorový konektor Power connector Motorstecker	Signální konektor Signal connector Signalstecker
<p>1 U 2 W 3 V 4 GND 4 Brzda / Brake / Bremse - 6 Brzda / Brake / Bremse +</p> <p>Strana pájení protikusu konektoru Ansicht Gegenstecker-Lötseite View from solder side of mating plugs</p>	<p>1 S1 7,8 Teplotní spínač 2 S3 Termoswitch 3 S4 Termoschalter 4 S2 5 R1 9,10 Si - Sensor (KTY 84-130) 6 R2 Si - Sensor (KTY 84-130) Si - Sensor (KTY 84-130)</p> <p>Strana pájení protikusu konektoru Ansicht Gegenstecker-Lötseite View from solder side of mating plugs</p>

Technická data – viz MA50

Technical datas – see MA50

Technische Daten – siehe MA50

M 25

M 40

M 50

M 71

M 90

F 50

F 63

F 80

F 100

W 25

W 40

W 50

W 71

W 90

ML 40

ML 50

ML 71

ML 90

MA 40

MA 50

ME

FE

- Typ
- Type
- Typ
- M 25
- M 40
- M 50
- M 71
- M 90
- F 50
- F 63
- F 80
- F 100
- W 25
- W 40
- W 50
- W 71
- W 90
- ML 40
- ML 50
- ML 71
- ML 90
- MA 40
- MA 50**
- ME
- FE



MA 504
MA 506
MA 508

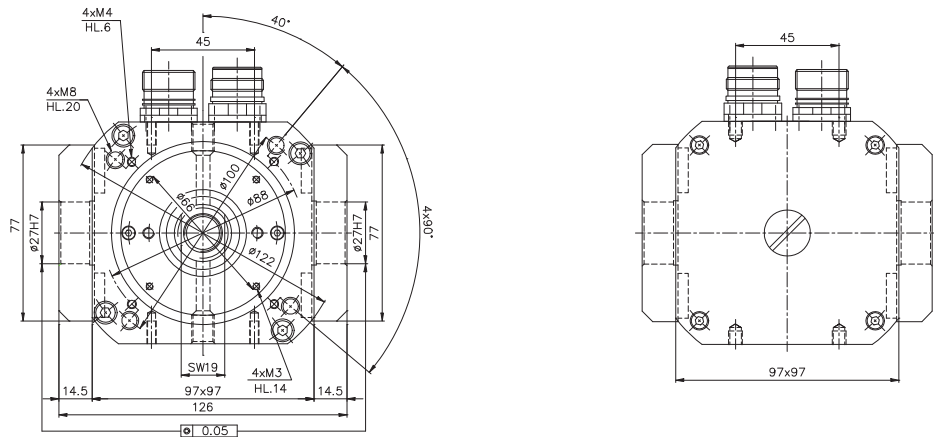
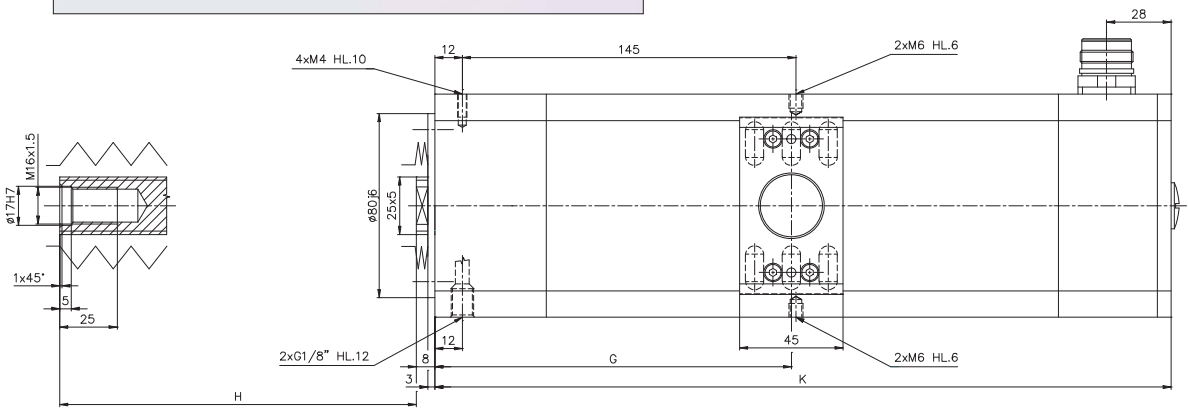

TYP SERVOMOTORU			
MOTOR TYPE	K	H	G
MOTORTYP			
MA 504	275	110	130
MA 506	320	155	155
MA 508	365	200	180



◆ Radiální a axiální zatížení volného konce ◆ Radial and axial shaft load capacity ◆
 ◆ Zulässige Radial- und Axialbelastungen der Wellenenden ◆

POZOR : ŽÁDNÉ RADIÁLNÍ ZATÍŽENÍ LOŽISKOVÉHO ŠROUBU !!!
ATTENTION : NO RADIAL LOAD CAPACITY OF A BALL SCREW !!!
VORSICHT : KEINE RADIALBELASTUNGEN DER KUGELGEWINDEANTRIEBEN !!!

		MA 504	MA 506	MA 508
F_{MAX}	N	20000	20000	20000
v_{MAX}	mm.s ⁻¹	260	260	260
n_{MAX}	rpm	3200	3200	3200

F_{MAX} - Maximální axiální zatížení ložiskového šroubu / Maximal axial load capacity of a ball screw / Maximale Axialbelastungen der Kugelgewindeantrieben /
 v_{MAX} - Maximální rychlost posuvu / Max. speed of shift / Maximale Verfahrgeschwindigkeit
 n_{MAX} - Maximální otáčky / Maximal speed / Max. Drehzahl

◆ Konektory ◆ Connectors ◆ Stecker ◆

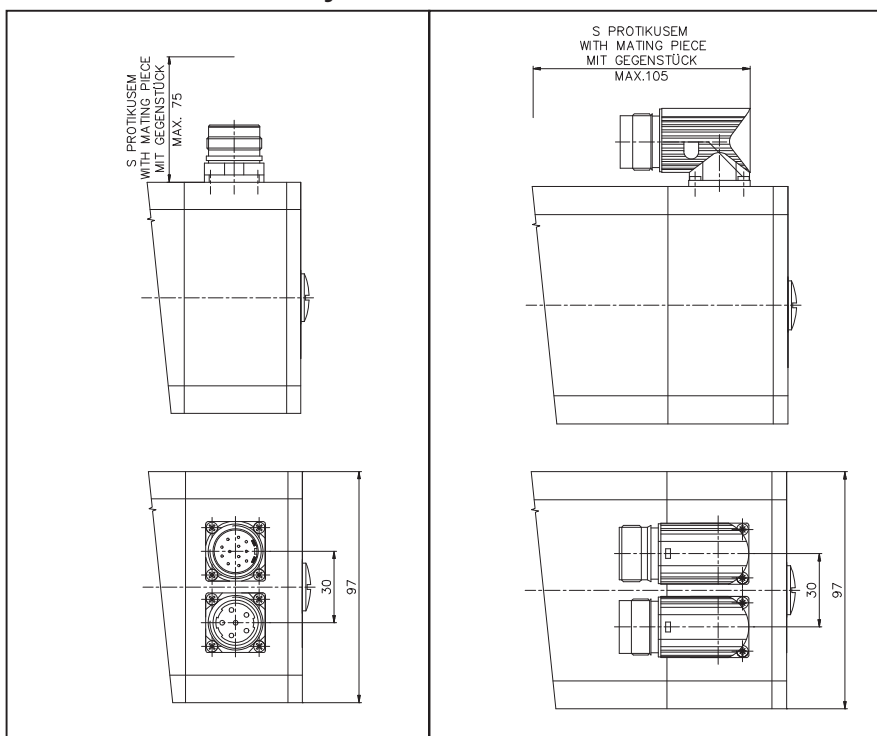

Motorový konektor Power connector Motorstecker	Signální konektor Signal connector Signalstecker
<p>1 U 2 W 3 V 4 GND 4 Brzda / Brake / Bremse - 6 Brzda / Brake / Bremse +</p> <p>Strana pájení protikusu konektoru Ansicht Gegenstecker-Lötseite View from solder side of mating plugs</p>	<p>1 S1 7,8 Teplotní spínač 2 S3 Termoswitch 3 S4 Termoschalter 4 S2 5 R1 9,10 Si - Sensor (KTY 84-130) 6 R2 Si - Sensor (KTY 84-130) Si - Sensor (KTY 84-130)</p> <p>Strana pájení protikusu konektoru Ansicht Gegenstecker-Lötseite View from solder side of mating plugs</p>

Typ
Type
Typ

M 25

M 40

M 50

M 71

M 90

F 50

F 63

F 80

F 100

W 25

W 40

W 50

W 71

W 90

ML 40

ML 50

ML 71

ML 90

MA 40

MA 50

ME

FE

Typ Type Typ	M 25	M 40	M 50	M 71	M 90	F 50	F 63	F 80	F 100	W 25	W 40
	W 50	W 71	W 90	ML 40	ML 50	ML 71	ML 90	MA 40	MA 50	ME	FE

Technical data of servomotors

TYPE OF THE MOTOR			MA404D	MA404F	MA404I	MA406D	MA406F	MA406I	MA408D	MA408E	MA408F	MA408I	MA408I	MA504D
Voltage of intermediate circuit of converter	U_{DC}	V	120	330	560	120	330	330	120	120	330	330	560	120
S STANDSTILL VALUES														
Standstill torque	M_0	Nm	1,1	1,1	1,1	2,1	2,1	2,1	2,7	2,7	2,7	2,7	2,7	3,8
Force by M_0	F_0	N	1382	1382	1382	2638	2638	2638	3391	3391	3391	3391	3391	4773
Standstill current	I_0	A	2,7	1,5	0,7	5,1	2,8	1,4	6,5	5,4	3,6	1,8	1,8	9,2
Torque constant	k_M	Nm/A	0,413	0,744	1,489	0,413	0,744	1,489	0,413	0,496	0,744	1,489	1,489	0,413
Force constant	k_F	N/A	519	935	1870	519	935	1870	519	623	935	1870	1870	519
N RATED VALUES OF THE MOTOR														
Rated voltage	$U_{N,MOT}$	V	51	157	225	58	148	163	56	52	146	156	291	56
Rated torque	M_N	Nm	1,0	1,0	1,0	1,9	1,8	2,0	2,4	2,5	2,2	2,5	2,2	3,4
Rated force	F_N	N	1297	1213	1269	2395	2274	2456	2975	3079	2767	3079	2767	4213
Rated current	I_N	A	2,6	1,4	0,7	4,7	2,5	1,3	5,9	5,0	3,1	1,7	1,5	8,4
Rated speed	n_N	min ⁻¹	1500	3000	2000	2000	3000	1500	2000	1500	3000	1500	3000	2000
Rated speed of moving	v_N	mm/s	125,0	250,0	166,7	166,7	250,0	125,0	166,7	125,0	250,0	125,0	250,0	166,7
Rated power output	P_N	W	162	304	212	399	569	307	496	385	692	385	692	702
Voltage constant	K_E	Vmin/1000	25	45	90	25	45	90	25	30	45	90	90	25
Voltage constant	k_b	Vs/rad	0,239	0,430	0,859	0,239	0,430	0,859	0,239	0,286	0,430	0,859	0,859	0,239
Ü OVERLOADING CAPACITY AT RATED SPEED														
Overloading capacity at rated speed	M_0	Nm	2,4	2,2	3,0	4,4	5,8	3,7	6,6	7,4	7,7	5,7	5,1	9,1
Max. overloading capacity at rated speed	M_0/M_N	-	2,35	2,33	2,97	2,31	3,23	1,90	2,80	3,02	3,51	2,34	2,31	2,72
VALUES OF THE MOTOR AT MAX. SUPPLY VOLTAGE U_1														
Max MAX. VALUES OF THE MOTOR														
Max. torque	M_{max}	Nm	5,3	5,3	5,3	10,1	10,1	10,1	12,9	12,9	12,9	12,9	12,9	20,2
Max. current	I_{max}	A	14,4	7,0	4,0	27,0	15,6	7,7	35,0	29,0	20,0	9,7	9,7	54,0
Max. speed	n_{mech}	min ⁻¹	3200	3200	3200	3200	3200	3200	3200	3200	3200	3200	3200	3200
C LIMIT POINT														
Current	I_C	A	12,6	7,0	4,0	27,0	15,6	7,7	35,0	29,0	20,0	9,7	9,7	54,0
Breakdown torque	M_C	Nm	5,2	4,8	5,0	10,0	9,9	10,1	12,4	12,5	11,9	12,6	12,1	19,5
Speed	n_C	min ⁻¹	0	1602	843	953	2088	421	1261	897	2275	731	1964	1033
Nutz MAX. UTILIZABLE PARAMETERS FOR S1														
Max. utilizable speed	n_{nutz}	min ⁻¹	2264	3727	3165	2477	3925	1805	2560	2093	3985	1875	3438	2551
Max. utilizable torque	M_{nutz}	Nm	1,0	0,9	1,0	1,9	1,7	1,9	2,3	2,4	2,0	2,4	2,1	3,2
Max. utilizable power output	P_{nutz}	W	237	364	318	483	708	364	610	516	851	469	767	863
O NO-LOAD RUNNING (I and M = 0)														
No-load speed	n_0	min ⁻¹	2800	4222	3667	2800	4222	2111	2800	2333	4222	2111	3667	2800
TECHNICAL FEATURES														
Number of poles	p	-	6	6	6	6	6	6	6	6	6	6	6	6
Resistance of winding	$R_{U,V}$	Ω	4,14	12,44	50,42	1,30	3,87	15,93	0,79	1,13	2,61	9,84	9,84	0,44
Inductance of winding	$L_{U,V}$	mH	6,28	19,23	76,24	2,80	8,84	36,52	1,87	2,70	6,54	25,60	25,60	2,50
Moment of inertia	J	kgm ² /1000	0,278	0,278	0,278	0,325	0,325	0,325	0,361	0,361	0,361	0,361	0,361	1,069
Mass	m	kg	5,2	5,2	5,2	7,3	7,3	7,3	9	9	9	9	9	13
Max. axial loading of the motor	F_A	N	10000	10000	10000	10000	10000	10000	10000	10000	10000	10000	10000	20000
Ball screw lead	w_2	mm	5	5	5	5	5	5	5	5	5	5	5	5
Ball screw stroke	h	mm	64	64	64	100	100	100	127	127	127	127	127	110
MECHANICAL VALUES OF THE MOTOR														
Static friction torque	M_f	Nm	0,075	0,075	0,075	0,1	0,1	0,1	0,125	0,125	0,125	0,125	0,125	0,168
Damping constant	k_D	Nm.min.10 ⁻⁵	0,70	0,70	0,70	0,90	0,90	0,90	1,80	1,80	1,80	1,80	1,80	2,50
Mechanical time constant	T_m	ms	10,1	9,4	9,5	3,7	3,4	3,5	2,5	2,5	2,5	2,4	2,4	4,1
THERMAL VALUES OF THE MOTOR														
Thermal resistance (winding–ambient atm.)	$R_{th(RU)}$	K/W	1,37	1,24	1,36	1,13	1,06	1,24	1,07	1,16	0,91	1,18	0,94	0,90
Thermal resistance (frame–ambient atm.)	$R_{th(GU)}$	K/W	1,11	1,00	1,10	0,92	0,86	1,00	0,87	0,94	0,74	0,96	0,76	0,73
Thermal time constant	T_{th}	min	21,7	19,6	21,6	25,3	23,7	27,7	29,3	31,6	24,9	32,3	25,6	38,4
COOLER														
Quantity of water	Q_w	dm ³ .min ⁻¹	-	-	-	-	-	-	-	-	-	-	-	-
Rated pressure of water	p_N	kPa	-	-	-	-	-	-	-	-	-	-	-	-
Quantity of air	Q_L	dm ³ .s ⁻¹	-	-	-	-	-	-	-	-	-	-	-	-

Typ Type Typ	M 25	M 40	M 50	M 71	M 90	F 50	F 63	F 80	F 100	W 25	W 40
	W 50	W 71	W 90	ML 40	ML 50	ML 71	ML 90	MA 40	MA 50	ME	FE

Technical data of servomotors

MA504G	MA504I	MA504I	MA506 G	MA506 G	MA506 I	MA506 I	MA506 L	MA508 F	MA508 H	MA508 L	MA508 L	TYPE OF THE MOTOR
330	330	560	120	330	330	560	560	120	330	330	560	
												S STANDSTILL VALUES
3,8	3,8	3,8	5,7	5,7	5,7	5,7	5,7	7,5	7,5	7,5	7,5	Standstill torque M_0 Nm
4773	4773	4773	7159	7159	7159	7159	7159	9420	9420	9420	9420	Force by M_0 F_0 A
4,6	2,6	2,6	6,9	6,9	3,8	3,8	2,9	10,1	7,6	3,8	3,8	Standstill current I_0 A
0,827	1,489	1,489	0,827	0,827	1,489	1,489	1,985	0,744	0,992	1,985	1,985	Torque constant k_M Nm/A
1039	1870	1870	1039	1039	1870	1870	2493	935	1246	2493	2493	Force constant k_F
												N RATED VALUES OF THE MOTOR
162	154	291	57	158	150	286	261	51	128	135	254	Rated voltage $U_{N,MOT}$ V
3,1	3,5	3,1	5,3	4,5	5,1	4,5	4,9	6,7	5,9	6,7	5,9	Rated torque M_N Nm
3933	4353	3933	6638	5595	6377	5595	6116	8428	7436	8428	7436	Rated force F_N
4,0	2,4	2,2	6,5	5,6	3,5	3,1	2,5	9,1	6,1	3,4	3,1	Rated current I_N A
3000	1500	3000	1000	3000	1500	3000	2000	1000	2000	1000	2000	Rated speed n_N min ⁻¹
250,0	125,0	250,0	83,3	250,0	125,0	250,0	166,7	83,3	166,7	83,3	166,7	Rated speed of moving v_N
984	544	984	553	1399	798	1399	1020	703	1240	703	1240	Rated power output P_N W
50	90	90	50	50	90	90	120	45	60	120	120	Voltage constant K_E Vmin/1000
0,477	0,859	0,859	0,477	0,477	0,859	0,859	1,146	0,430	0,573	1,146	1,146	Voltage constant k_a Vs/rad
												Ü OVERLOADING CAPACITY AT RATED SPEED
7,7	8,9	6,8	14,3	15,1	14,7	11,2	14,9	27,5	31,8	28,1	26,3	Overloading capacity at rated speed $M_Ü$ Nm
2,47	2,55	2,18	2,70	3,40	2,89	2,51	3,05	4,10	5,36	4,18	4,44	Max. overloading capacity at rated speed $M_Ü/M_N$ -
												VALUES OF THE MOTOR AT MAX. SUPPLY VOLTAGE U_1
												Max MAX. VALUES OF THE MOTOR
20,2	20,2	20,2	30,3	30,3	30,3	30,3	30,3	40,0	40,0	40,0	40,0	Max. torque M_{max} Nm
27,5	15,0	15,0	34,0	34,0	23,0	23,0	17,5	47,0	39,0	20,0	20,0	Max. current I_{max} A
3200	3200	3200	3200	3200	3200	3200	3200	3200	3200	3200	3200	Max. speed n_{mech} min ⁻¹
												C LIMIT POINT
27,5	15,0	15,0	34,0	34,0	23,0	23,0	17,5	47,0	39,0	20,0	20,0	Current I_C A
19,1	19,7	19,1	29,9	28,8	29,7	29,1	29,5	39,5	38,8	39,5	38,9	Breakdown torque M_C Nm
1663	718	1596	572	2200	825	1741	1183	760	1725	758	1616	Speed n_C min ⁻¹
												Nutz MAX. UTILIZABLE PARAMETERS FOR S1
3557	1894	3432	1249	3639	1936	3487	2570	1423	3037	1461	2635	Max. utilizable speed n_{nutz} min ⁻¹
3,0	3,4	3,0	5,2	4,2	4,9	4,3	4,6	6,4	5,1	6,3	5,4	Max. utilizable torque M_{nutz} Nm
1120	670	1091	678	1596	993	1553	1247	950	1622	971	1495	Max. utilizable power output P_{nutz} W
												O NO-LOAD RUNNING (I and M = 0)
3800	2111	3667	1400	3800	2111	3667	2750	1556	3167	1583	2750	No-load speed n_0 min ⁻¹
												TECHNICAL FEATURES
6	6	6	6	6	6	6	6	6	6	6	6	Number of poles p -
1,84	5,26	5,26	0,81	0,81	2,95	2,95	5,24	0,46	0,81	3,20	3,20	Resistance of winding R_{U-V} Ω
8,60	30,24	30,24	5,30	5,30	18,12	18,12	32,61	3,16	5,99	18,50	18,50	Inductance of winding L_{U-V} mH
1,069	1,069	1,069	1,220	1,220	1,220	1,220	1,220	1,371	1,371	1,371	1,371	Moment of inertia J kgm ² /1000
13	13	13	18	18	18	18	18	22,7	22,7	22,7	22,7	Mass m kg
20000	20000	20000	20000	20000	20000	20000	20000	20000	20000	20000	20000	Max. axial loading of the motor F_A N
5	5	5	5	5	5	5	5	5	5	5	5	Ball screw lead w_2 N
110	110	110	155	155	155	155	155	200	200	200	200	Ball screw stroke h min ⁻¹
												MECHANICAL VALUES OF THE MOTOR
0,168	0,168	0,168	0,27	0,27	0,27	0,27	0,27	0,33	0,33	0,33	0,33	Static friction torque M_f Nm
2,50	2,50	2,50	4,00	4,00	4,00	4,00	4,00	5,20	5,20	5,20	5,20	Damping constant k_D Nm.min.10 ⁻⁵
4,3	3,8	3,8	2,2	2,2	2,4	2,4	2,4	1,7	1,7	1,7	1,7	Mechanical time constant T_m ms
												THERMAL VALUES OF THE MOTOR
0,73	1,04	0,77	0,95	0,57	0,79	0,55	0,70	0,83	0,65	0,84	0,65	Thermal resistance (winding–ambient atm.) $R_{th(RU)}$ K/W
0,59	0,84	0,62	0,77	0,46	0,64	0,45	0,57	0,67	0,53	0,68	0,53	Thermal resistance (frame–ambient atm.) $R_{th(GU)}$ K/W
31,2	44,2	32,9	54,8	33,2	45,5	32,1	40,5	52,3	41,2	53,0	41,4	Thermal time constant T_{th} min
												COOLER
-	-	-	-	-	-	-	-	-	-	-	-	Quantity of water Q_w dm ³ .min ⁻¹
-	-	-	-	-	-	-	-	-	-	-	-	Rated pressure of water p_N kPa
-	-	-	-	-	-	-	-	-	-	-	-	Quantity of air Q_L dm ³ .s ⁻¹