

Nema 34

2 phase 1.8° step angle
 hybrid stepping motor

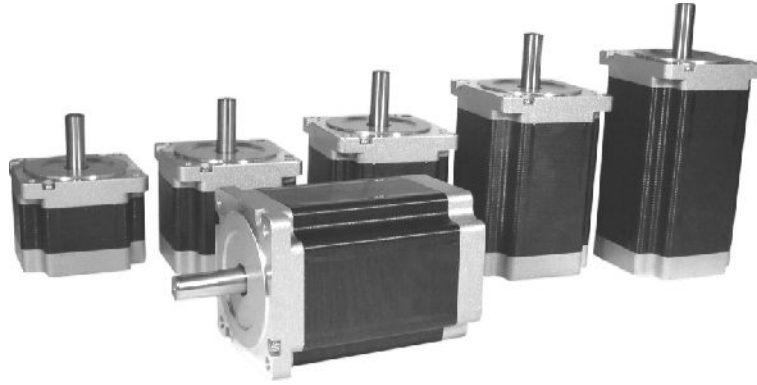

Specifications:

Model	Holding Torque (Nm)	Phase current (A)	Rotor Inertia (g/cm ²)	Motor Length L max (mm)	Detent Torque (Nm)	Phase Resistance (ohm)	Phase Inductance (mH)	Lead Wire (No)	Motor Weight (Kg)	Note
M1343011	3.1	5.6	850	63	0.055	0.26	0.8	8	1.9	Bip. parallel
M1343020	4.4	5.6	1050	78	0.065	0.35	1.5	8	2.3	Bip. parallel
M1343021	4.4	7.1	1050	78	0.065	0.21	0.9	8	2.3	Bip. Parallel
M1343031	6.8	7.1	1550	98	0.095	0.26	1.2	8	3	Bip. Parallel
M1343041	8.1	7.1	1800	114	0.13	0.38	1.6	8	3.8	Bip. parallel
M1343050	9.2	7.1	2200	126	0.19	0.43	1.7	8	4.1	Bip. parallel
M1343051	9.2	10	2200	126	0.19	0.18	0.9	8	4.1	Bip. Parallel
M1343061	12.1	12	2500	150	0.25	0.17	0.9	8	5	Bip. parallel

Mechanical Dimensions:
 Unit: mm

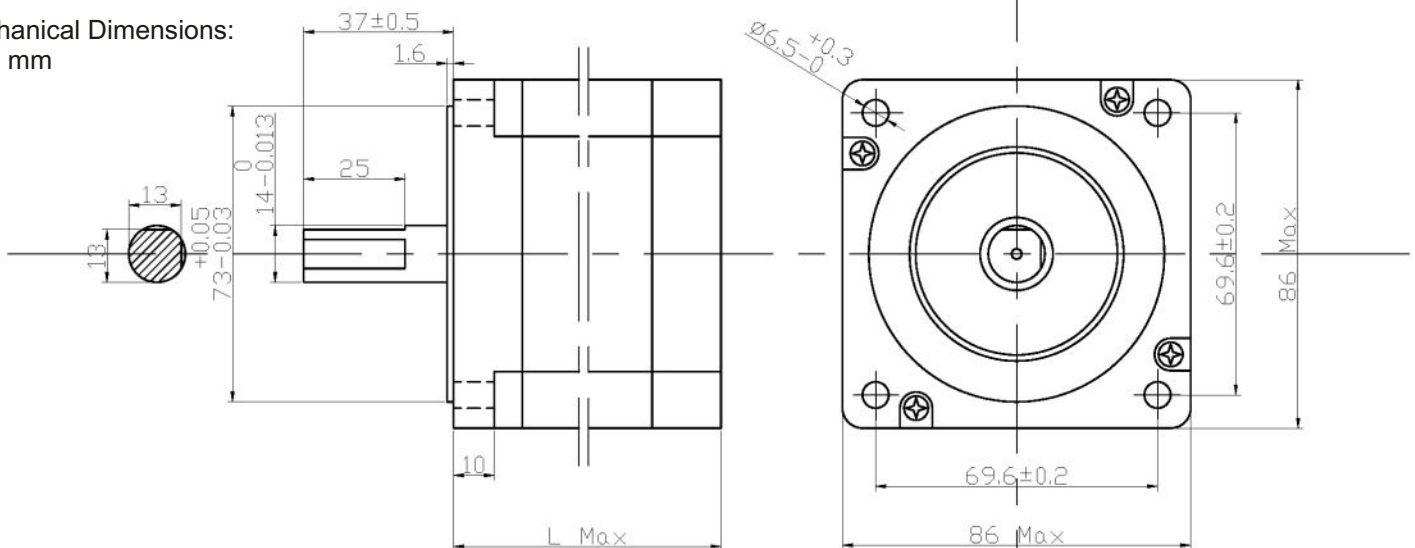

Wiring Diagram:

